

This file provided by

INFINITY

d a t a c o r p

Switch to Infinity Data Corp for your processing needs! Infinity offers great rates, excellent customer support and a wide range of payment processing solutions.

<http://www.infinitydata.com/>

Call Today!
Sales 1 800 393 6665

e^N-Scribe 612™

Installation Instructions

Introduction

The e^N-Scribe 612, shown in Figure 1, is a high-performance thermal receipt printer which has the following features:

- industry standard 42 column print format
- uses 3 inch (76mm) wide, single-ply thermal paper
- can be configured to print 1, 2, or 3 copies of a receipt
- operates at speeds of up to 12 lines per second
- simulates two color printing by printing red text in a reverse font
- has an RS-232 compatible interface port that allows you to connect it to a variety of POS terminal applications, including those presently set-up for use with the Verifone® Printer 250

Figure 1: e^N-Scribe 612

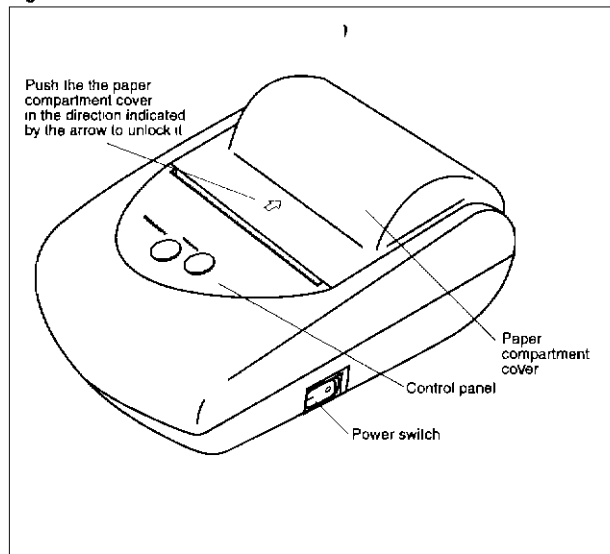

Unpacking the printer components

The e^N-Scribe 612 printer comes with the parts shown in Figure 2. Verify that the following pieces have been received and that no parts have been damaged in shipment:

- e^N-Scribe 612 printer
- paper roll
- two-part paper roll spindle
- power adapter

Figure 2: e^N-Scribe 612 components

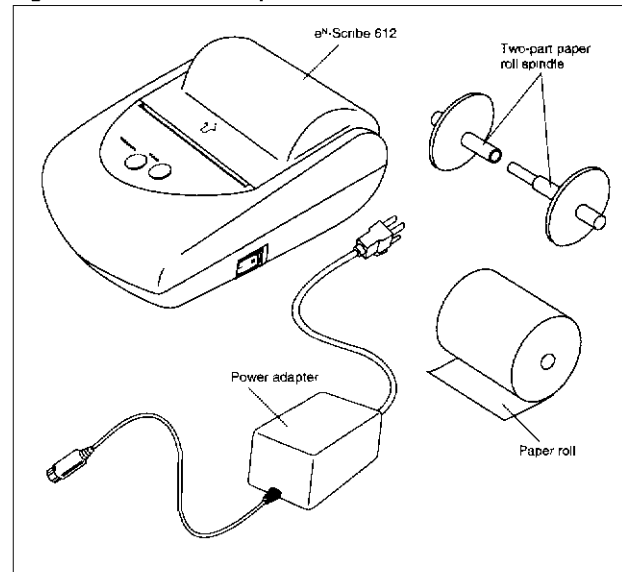

Since the e^N-Scribe 612 can connect to a variety of terminals, an interface cable is not included in the package. The interface cable required for your terminal application can be ordered separately.

If any parts have been damaged, contact the carrier who delivered the shipment for instructions on how to return the printer for replacement.

Selecting a location

The e^N-Scribe 612 can be either set on a flat surface or mounted on a wall. When selecting a location, choose a place that allows the printer adequate ventilation and that allows room for the connection of power and interface cables. The location should be near enough to both the terminal and 120 volt wall outlet so that there is no undue strain on the attached cables. The final printer position should also make it easy for the operator to change the paper roll and to tear off printed receipts.

Troubleshooting

Paper jams

Though not common, the paper may get jammed in the printer's feed mechanism. You can correct the paper jam by repeating the instructions in *Installing a new paper roll*, only use the same roll and make sure that all the paper has been fed through.

Printer does not turn on

1. Check that the power adapter is plugged into a 120 volt AC outlet.
2. Check that the power adapter cable is firmly inserted into the Power jack on the e^N-Scribe 612.
3. Verify that power is available at the outlet.

Printer does not print

1. Check that the interface cable is securely plugged into the RS-232 port on the e^N-Scribe 612.
2. Check that the interface cable is securely plugged into the appropriate port on the terminal.
3. Run a Self-Test (see *Basic operation*) to determine whether the printer itself is functional. A proper result to the Self-Test indicates that there is a communication problem between the terminal and the e^N-Scribe 612. If the Self-Test does not run properly, contact the customer service center.
4. Check the configuration settings required by your terminal application by entering Configuration mode (see *Configuring the e^N-Scribe 612*). Make any changes necessary.

If your printer is still not working correctly after performing these checks and tests, call the customer service centers listed below:

In Canada:

RBA Inc.
3190 Orlando Drive
Mississauga, Ontario
L4V 1R5
1-800-387-3938 or (905) 672-1048

In the U.S.A.:

IVI Checkmate Inc.
Customer Service Center
1335 North Meadow Parkway, Suite 116
Atlanta, Georgia 30076
1-800-435-3014
Fax: (770) 594-6006 or (770) 594-6026

Maintaining the e^N-Scribe 612

Cleaning the case

Remove dust from the e^N-Scribe 612 using a damp cloth. To wash off accumulated dirt and grime, use mild soap and water. Do not allow water to enter inside the case.



CAUTION

Do not use solvents, cleaning fluids, or abrasives on the e^N-Scribe 612. These materials could damage the plastic housing.

US Federal Communications Commission (FCC) Warnings:

This equipment has been tested and found to comply with the limits for a Class A digital device, pursuant to Part 15 of the FCC Rules. These limits are designed to provide reasonable protection against harmful interference when this equipment is operated in a commercial environment. This equipment generates, uses, and can radiate radio frequency energy and, if not installed and used in accordance with the instruction manual, may cause harmful interference to radio communications. Operation of this equipment in a residential area is likely to cause harmful interference in which case the user will be required to correct the interference at his own expense.

Canadian Department of Communications (DOC) Warnings:

This digital apparatus does not exceed the Class A limits for radio noise emissions from the digital apparatus as set out in the radio interference regulations of the Canadian Department of Communications.



Copyright © 1999
IVI Checkmate Corp.
130-00612-0100

Connecting the terminal and power

Connecting the serial interface cable

1. Insert the 8-pin mini DIN connector of the interface cable into the RS-232 port, as shown in Figure 3.
2. Insert the other end of the interface cable into the appropriate port on the terminal (consult the manufacturer's documentation to determine which port to use).

Connecting to the power supply

1. Insert the 4-pin mini DIN connector of the supplied power adapter cable into the Power jack, as shown in Figure 3.
2. Insert the three-pronged plug on the other end of the cable into a grounded 120 volt wall outlet.



Warning

Do not plug the power pack into an outdoor electrical outlet or operate the eⁿ-Scribe 612 outdoors. Disconnecting power during data processing can result in loss of data.

Figure 3: eⁿ-Scribe 612 ports

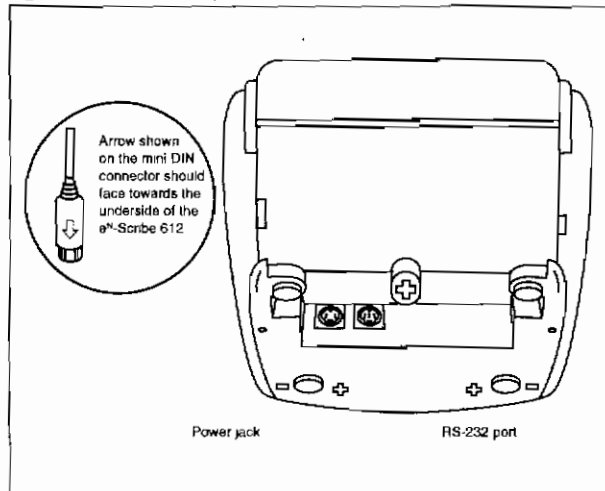

Installing a new paper roll

1. Unlock the paper compartment cover by pushing the cover back from the closed position (push the cover in the direction of the arrows, as shown in Figure 1). Lift the cover to open the paper compartment—the cover opens on its rear hinge as you lift. If you are installing the paper roll for the first time, skip to step 4.
2. Cut or tear off any remaining part of the existing paper roll. Remove the spindle from inside the paper roll and set it aside. Discard the used roll.
3. Press the *Feed* button to feed the remaining paper through the printer and then discard it. Do not pull the paper through the mechanism.
4. Unfasten the end of the new paper roll and tightly fold over one corner on the end to form a sharp point, as shown in Figure 4.
5. Insert the spindle into the new paper roll. Place the roll and spindle into the paper roll compartment with the paper feeding from the bottom as shown in Figure 4.
6. Pull up the printhead lever and insert the pointed end of the paper roll into the slot at the front of the paper compartment until the paper appears through the tear bar. Pull the paper through until the folded portion is clear of the tear bar.
7. Lower the printhead lever and press the *Feed/Copy* button to feed the paper through the mechanism until about two inches of paper is showing.
8. Tear off the excess paper using the tear bar and close the paper compartment cover. Push the cover in the reverse direction of the arrows until the locking tabs clicks it into the locked position.

Figure 4: installing a new paper roll

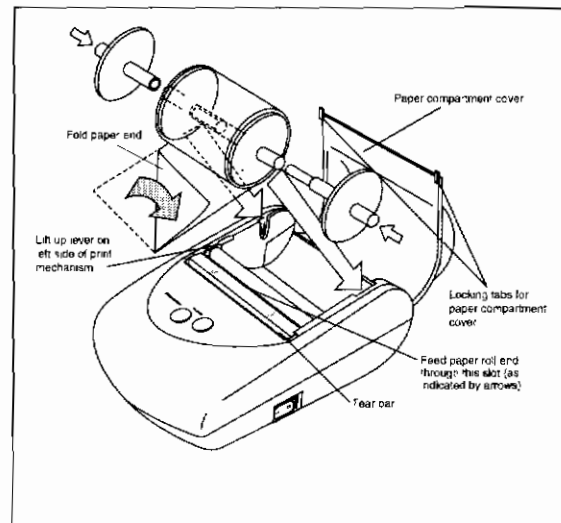

Basic operations

The Control Panel shown in Figure 5 provides you with a power indicator, the *Feed/Copy* button, and the *Clear* button.

Power indicator

Turns green when the printer is powered-up. Indicator blinks when a receipt is waiting to be printed.

Feed/Copy button

Depress this button to feed paper through the print mechanism or to print a waiting receipt as indicated by the blinking power indicator. *Feed/Copy* is also used to perform a Self-Test (see below) and to scroll through the possible configuration menu options.

Clear button

Press this button to clear the print buffer when additional copies of the receipt are not required. *Clear* is also used to enter configuration mode and to select configuration settings.

Figure 5: e^N-Scribe 612 Control Panel

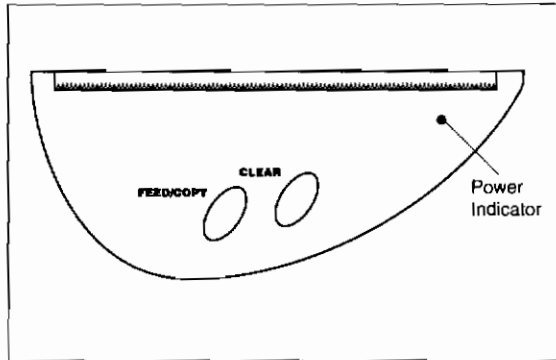

Performing a Self-Test

The e^N-Scribe 612 basic operations can be verified by activating the Self-Test.

To activate Self-Test mode:

1. Press and hold down the *Feed/Copy* button while turning on the printer (see Figure 1 for the location of the power switch).
2. Once printing starts, release the *Feed/Copy* button.
3. The current configuration settings and a sample of the available fonts are printed when the printer is operating normally. The e^N-Scribe 612 automatically exits Self-Test mode once the printing is complete.

Configuring the e^N-Scribe 612

The e^N-Scribe 612 has the following factory default communication settings:

- Parity—Even
- Word Length—7 bits
- Baud Rate—9600
- Copies to print—2
- Delay between copies—4 seconds
- Clear time—120 seconds
- Annotate—off

These settings are appropriate for many applications and may not need to be adjusted. If your terminal requires other settings, however, you can re-configure the e^N-Scribe 612 by entering Configuration mode and making the appropriate changes.

To enter Configuration mode and change the current settings:

1. Press and hold down the *Clear* button while turning on the printer (see Figure 1 for the location of the power switch).
2. Once printing starts, release the *Clear* button.
3. The current configuration settings are printed and you are presented with two options, as shown in Figure 6. You can press *Feed/Copy* to keep the existing settings and exit configuration mode, or you can press *Clear* to specify parameters.

Figure 6: Configuration Menu

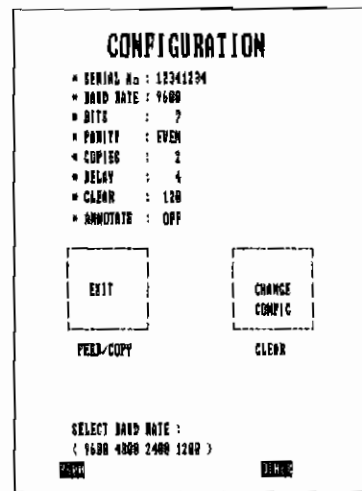

4. Press *Clear* to display the first configuration parameter (Select Baud Rate, as shown in Figure 6).
5. If the currently displayed value is correct, press *Feed/Copy* to advance to the next parameter. To change the setting, press *Clear* until the required setting is printed and then press *Feed/Copy* to advance to the next parameter.
6. Repeat step 5 for each of the remaining 6 parameters. Remember that *Clear* changes the value and *Feed/Copy* keeps the currently shown setting and advances to the next parameter.
7. Once you have advanced through all the configuration options, the configuration settings are re-printed, as shown in Figure 6. To keep the settings and return to normal printer mode, press *Feed/Copy* to exit. If further changes are required, press *Clear* and repeat steps 5-7.